

CH640A

64,000 LB First Layer Line Pull

BRADEN®

DIMENSIONAL INFORMATION

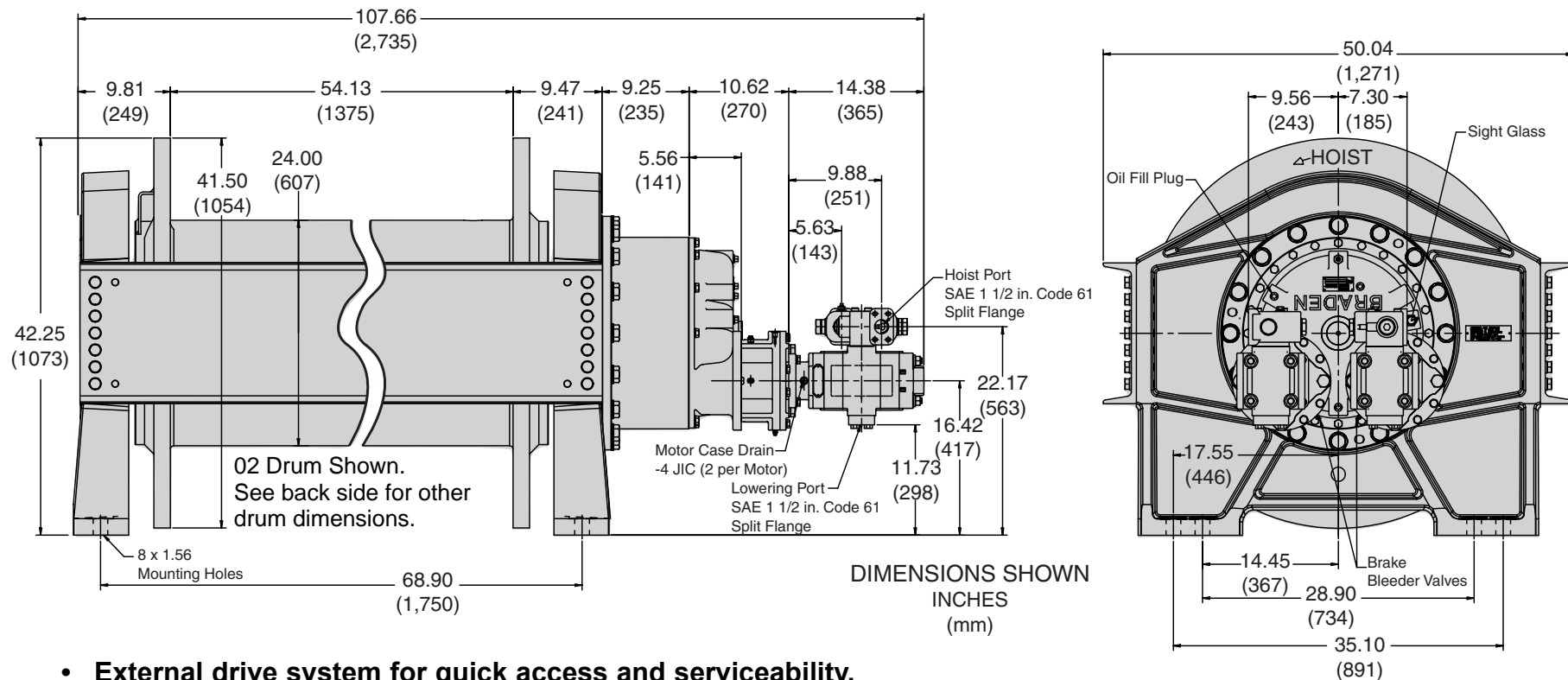

- External drive system for quick access and serviceability.
- Large selection on hydraulic motor displacements to optimize performance for your application.
- Dual or Single motor input for hydraulic flexibility and faster line speeds.
- Optional ratchet and pawl for boom hoist applications.
- Easily accessible oil sight glass and fill plug to ease maintenance.
- Optional drum sizes to provide the storage your application requires.

PACCAR WINCH DIVISION

P.O. Box 547 Broken Arrow, Oklahoma 74013
PHONE: (918) 251-8511 FAX: (918) 259-1575
www.paccarwinch.com

PERFORMANCE INFORMATION

CH640A-96D120-01-1 (Dual Gear Motors)

LAYER	Pressure		Flow		Rope Size	
	(psi)	(bar)	(gpm)	(lpm)	(in)	
	2900	200	300	1135	1 1/8	
LAYER	Line Pull		Line Speed		Rope	
	(lbs)	(kg)	(fpm)	(mpm)	(ft)	(m)
1	64,000	29,095	184	56	211	64
2	58,720	26,691	201	61	441	134
3	54,250	24,695	217	66	690	210
4	50,410	22,914	234	71	657	292
5	47,070	21,395	251	77	1,243	379
6	44,150	20,068	267	81	1,548	472
7	41,570	18,865	284	87	1,872	571

CH640A-66D120-01-1 (Dual Gear Motors)

LAYER	Pressure		Flow		Rope Size	
	(psi)	(bar)	(gpm)	(lpm)	(in)	
	2900	200	300	1135	1 1/8	
LAYER	Line Pull		Line Speed		Rope	
	(lbs)	(kg)	(fpm)	(mpm)	(ft)	(m)
1	43,990	19,995	268*	82	211	64
2	40,360	18,345	292	89	441	134
3	37,280	16,945	316	96	690	210
4	34,640	15,745	340	104	657	292
5	32,350	14,705	364	111	1,243	379
6	30,340	13,791	389	119	1,548	472
7	28,570	12,986	413	126	1,872	571

*Maximum First Layer Line Speed with Gear Motor

CH640A-66D090-01-1 (Dual Gear Motors)

LAYER	Pressure		Flow		Rope Size	
	(psi)	(bar)	(gpm)	(lpm)	(in)	
	3500	241	300	1135	1 1/8	
LAYER	Line Pull		Line Speed		Rope	
	(lbs)	(kg)	(fpm)	(mpm)	(ft)	(m)
1	37,870	17,214	350*	107	211	64
2	34,740	15,791	382	116	441	134
3	32,100	14,591	414	126	690	210
4	29,820	13,555	445	136	657	292
5	27,850	12,659	477	145	1,243	379
6	26,120	11,873	508	155	1,548	472
7	24,600	11,182	540	165	1,872	571

*Maximum First Layer Line Speed with Bushing Motor

WIRE ROPE CAPACITY

-01 DRUM (24.00B x 41.50F x 36.13L)

ROPE SIZE	LAYER							MAXIMUM LAYERS	Pitch Dia. Ratio
	FIRST		MID			TOP			
	(in.)	ft	m	ft	#	m	ft		
1	236	72	1058	4	322	2418	737	8	25:1
1 1/8	211	64	957	4	292	1872	571	7	22:1
1 1/4	191	58	628	3	191	1426	435	6	20:1

-02 DRUM (24.00B x 41.50F x 54.13L)

ROPE SIZE	LAYER							MAXIMUM LAYERS	Pitch Dia. Ratio
	FIRST		MID			TOP			
	(in.)	ft	m	ft	#	m	ft		
1	354	108	1585	4	483	3623	1104	8	25:1
1 1/8	316	96	1434	4	437	2807	856	7	22:1
1 1/4	286	87	942	3	287	2139	652	6	20:1

-21 DRUM (24.00B x 41.50F x 66.00L)

ROPE SIZE	LAYER							MAXIMUM LAYERS	Pitch Dia. Ratio
	FIRST		MID			TOP			
	(in.)	ft	m	ft	#	m	ft		
1	431	131	1933	4	589	4419	1347	8	25:1
1 1/8	385	117	1749	4	533	3424	1044	7	22:1
1 1/4	349	106	1150	3	351	2610	796	6	20:1

-22 DRUM (22.00B x 41.50F x 72.00L)

ROPE SIZE	LAYER							MAXIMUM LAYERS	Pitch Dia. Ratio
	FIRST		MID			TOP			
	(in.)	ft	m	ft	#	m	ft		
1	433	132	2542	5	775	5255	1602	9	23:1
1 1/8	387	118	1774	4	541	4151	1265	8	20:1
1 1/4	350	107	1626	3	496	3242	988	7	18:1

MODEL OPTIONS

GEAR RATIOS

66 (65.95:1)
80 (79.93:1)
86 (85.59:1)
96 (95.81:1)
102 (101.98:1)
128 (127.97:1)

DRUM SIZES

-01 (24.00B x 41.5F x 36.13L)
-02 (24.00B x 41.5F x 54.13L)
-21 (24.00B x 41.5F x 66.00L)
-23 (22.00B x 41.5F x 72.00L)

MOTOR SIZES

Consult the factory for the motor best suited for your application.

SPECIAL OPTIONS

P (ratchet and pawl)
U Underwind

▲ WARNING ▲

A minimum of 5 wraps of wire rope must be left on the drum to prevent the load from being supported by the wire rope anchor alone. Since the wire rope anchor is not designed to hold the rated load, failure to leave 5 wraps of wire rope on the drum could cause the load to drop, which could result in property damage, personal injury or death.

NOTES

Specifications are subject to change without notification and without incurring obligation.

Pressure and flow shown are the maximum allowable for the particular combination of winch, ratio, motor and drum.

Specifications in this publication are theoretical and may vary depending on hydraulic system, environment, etc.

Line pulls are maximum ratings for the winch only.

Wire rope ratings may be lower than the winch rating.

Consult the wire rope manufacturer for ratings.

CH640A